

Atera[®] SIGNO

Fiat Ducato
Peugeot Boxer

7/2006–
7/2006–

Citroen Jumper 7/2006–

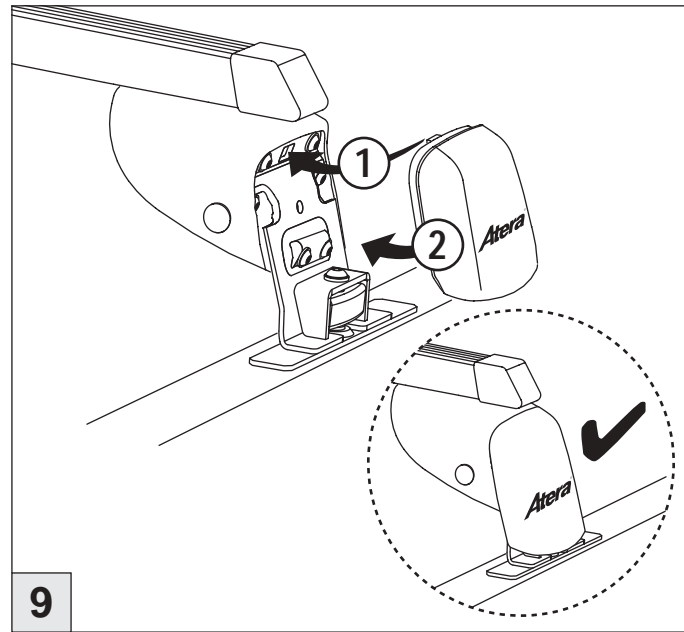
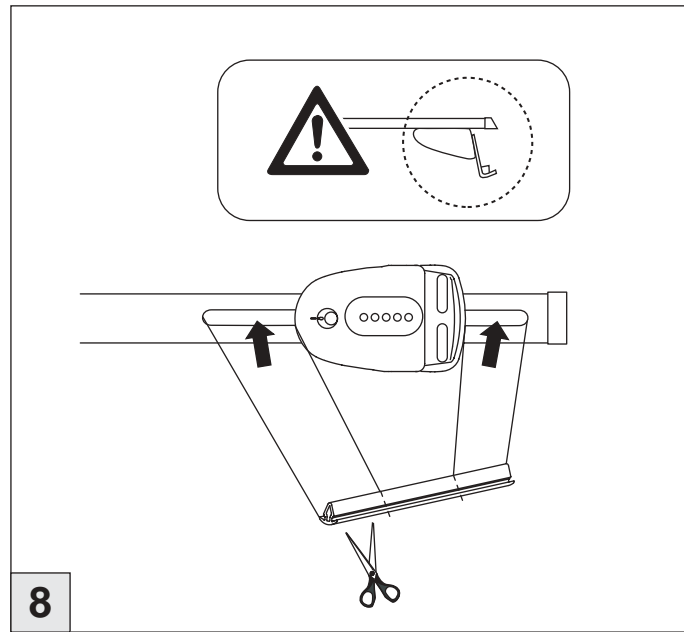

8

9

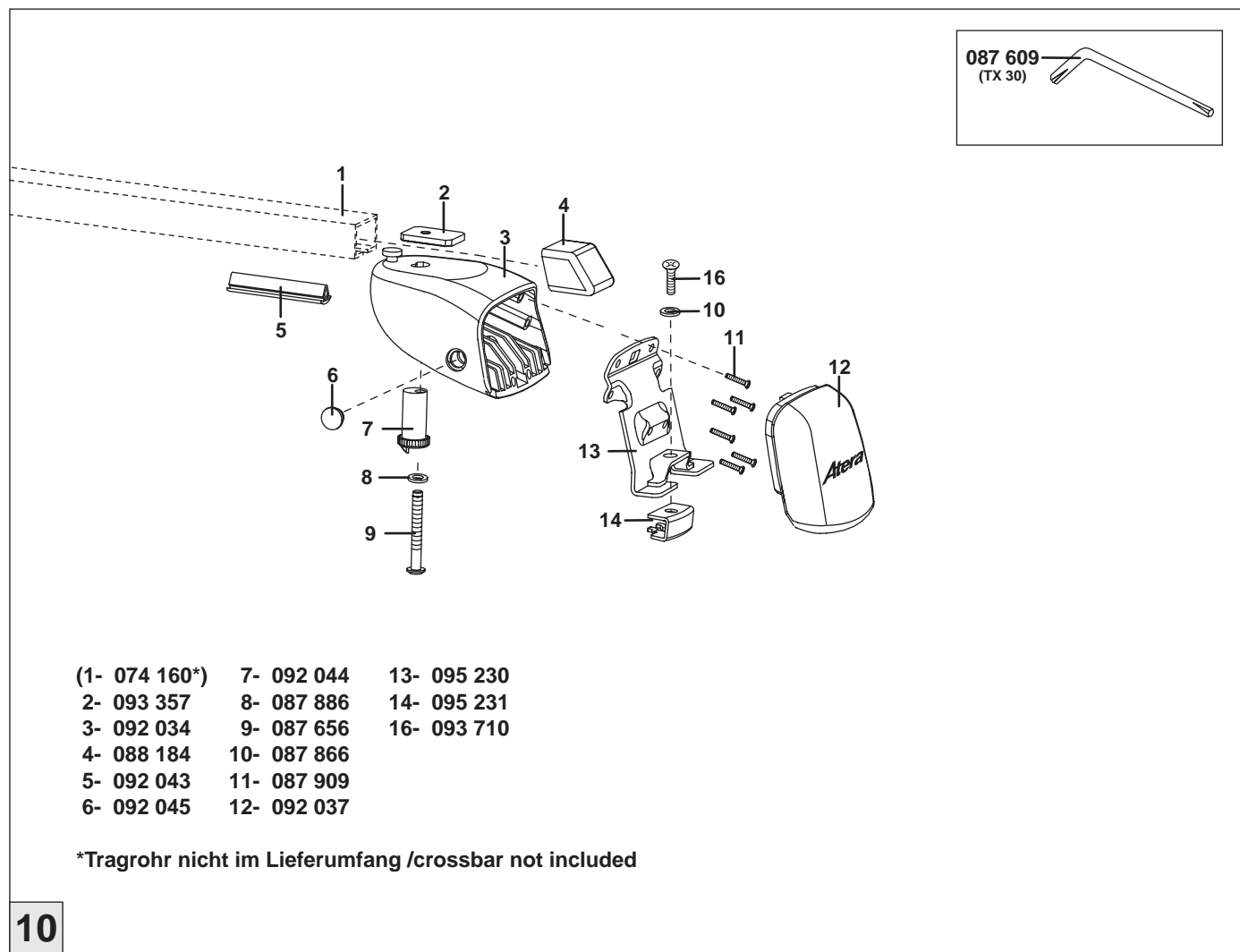

- | | | |
|---------------|-------------|-------------|
| (1- 074 160*) | 7- 092 044 | 13- 095 230 |
| 2- 093 357 | 8- 087 886 | 14- 095 231 |
| 3- 092 034 | 9- 087 656 | 16- 093 710 |
| 4- 088 184 | 10- 087 866 | |
| 5- 092 043 | 11- 087 909 | |
| 6- 092 045 | 12- 092 037 | |

*Tragrohr nicht im Lieferumfang /crossbar not included

10

Atera[®]
MADE IN GERMANY
Atera GmbH
Postfach 2240
D-88192 Ravensburg
Telefon 07 51 - 76 04-0
Telefax 07 51 - 76 04-76
E-Mail: info@atera.de

Atera[®] SIGNO

Fiat Ducato 07/2006–
Peugeot Boxer 07/2006–
Citroen Jumper H1/H2 07/2006–
Part-No. : 044 150

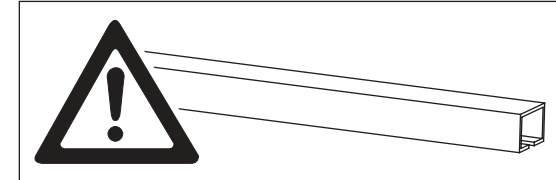
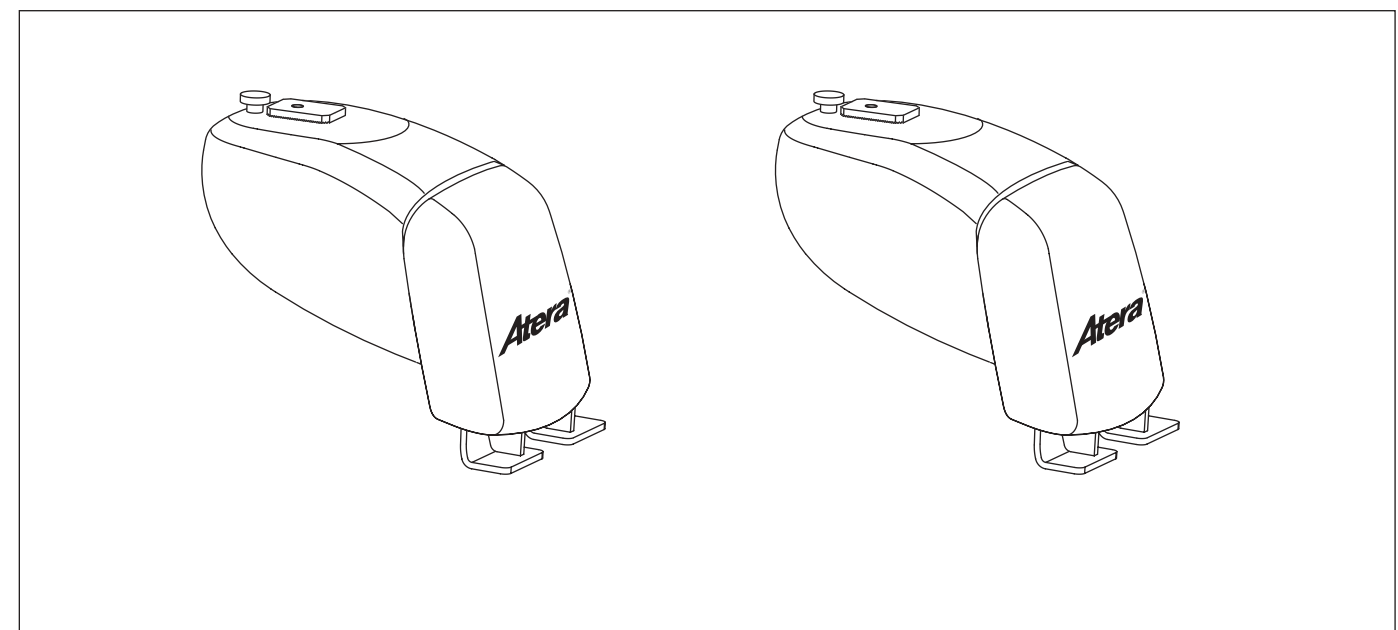
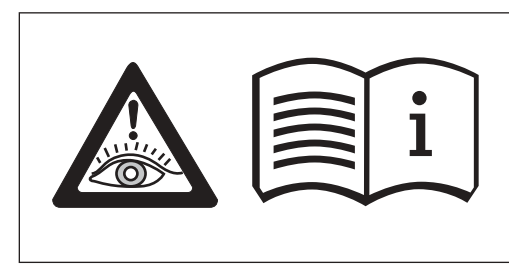

Stützfüße dürfen nur in Kombination mit original Atera-Tragrohren der Länge 1600 mm (Art.-Nr.: 074 160, nicht im Lieferumfang enthalten!) verwendet werden.
Supporting legs must be used only in combination with original carrier bars made by Atera with length of 1600 mm (Art. no.: 074 160, not included).

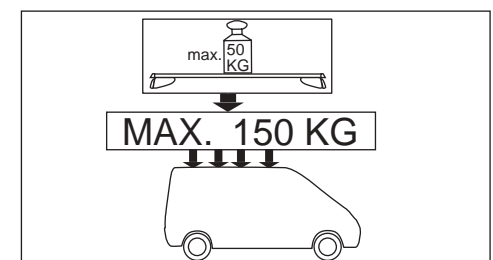
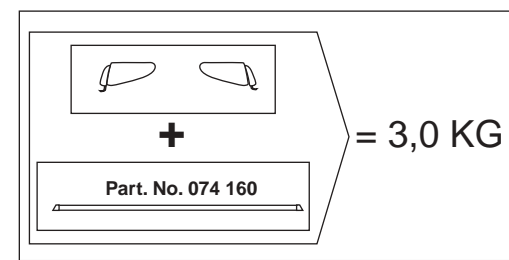

Atera[®] SIGNO

Fiat Ducato
Peugeot Boxer

7/2006–
7/2006–

Citroen Jumper 7/2006–

Atera[®] SIGNO

Fiat Ducato
Peugeot Boxer

7/2006–
7/2006–

Citroen Jumper 7/2006–

Tragrohr/cross bar (Part.No.= 074 160)

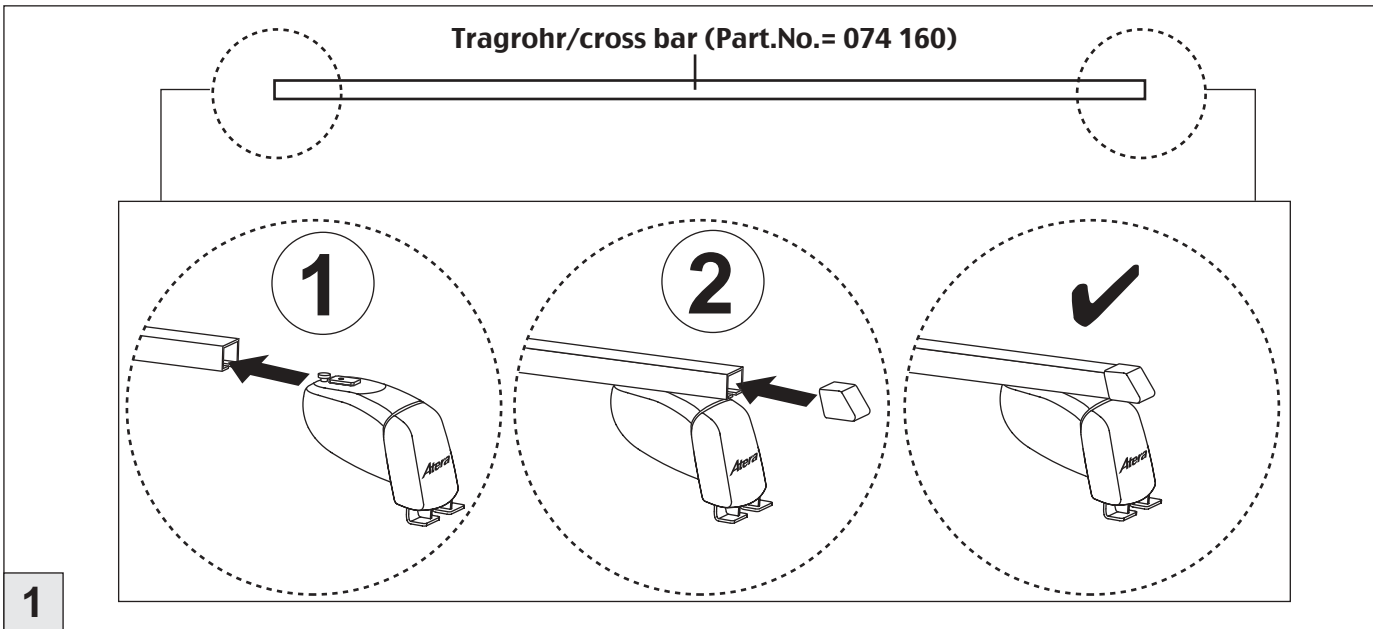

1

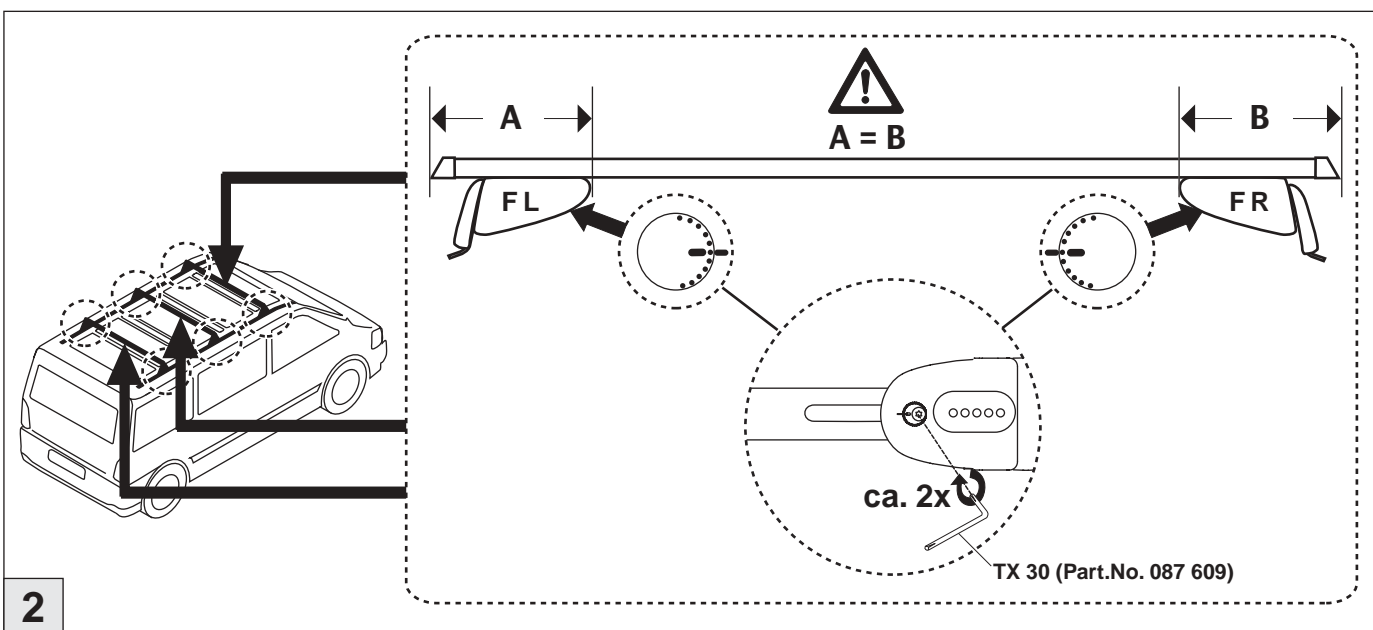

2

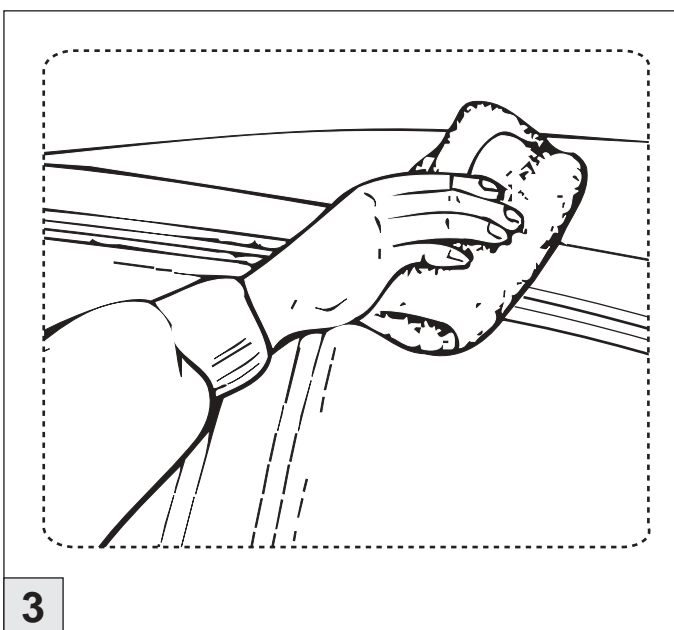

3

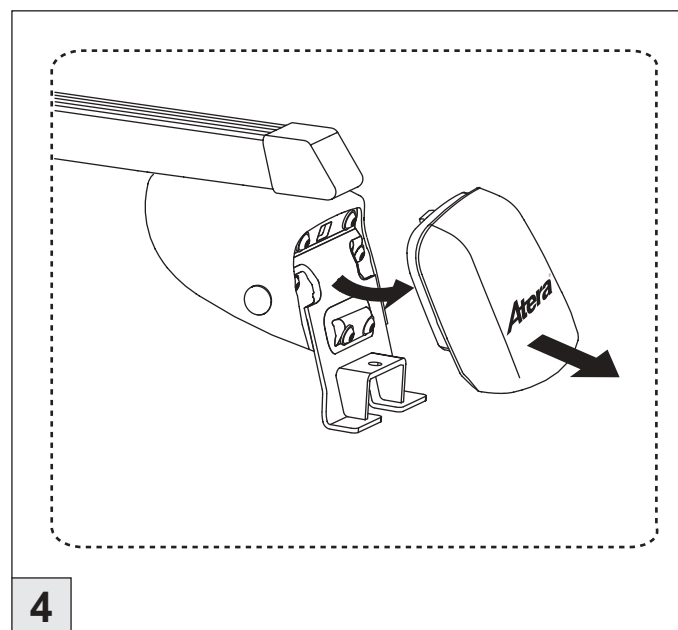

4

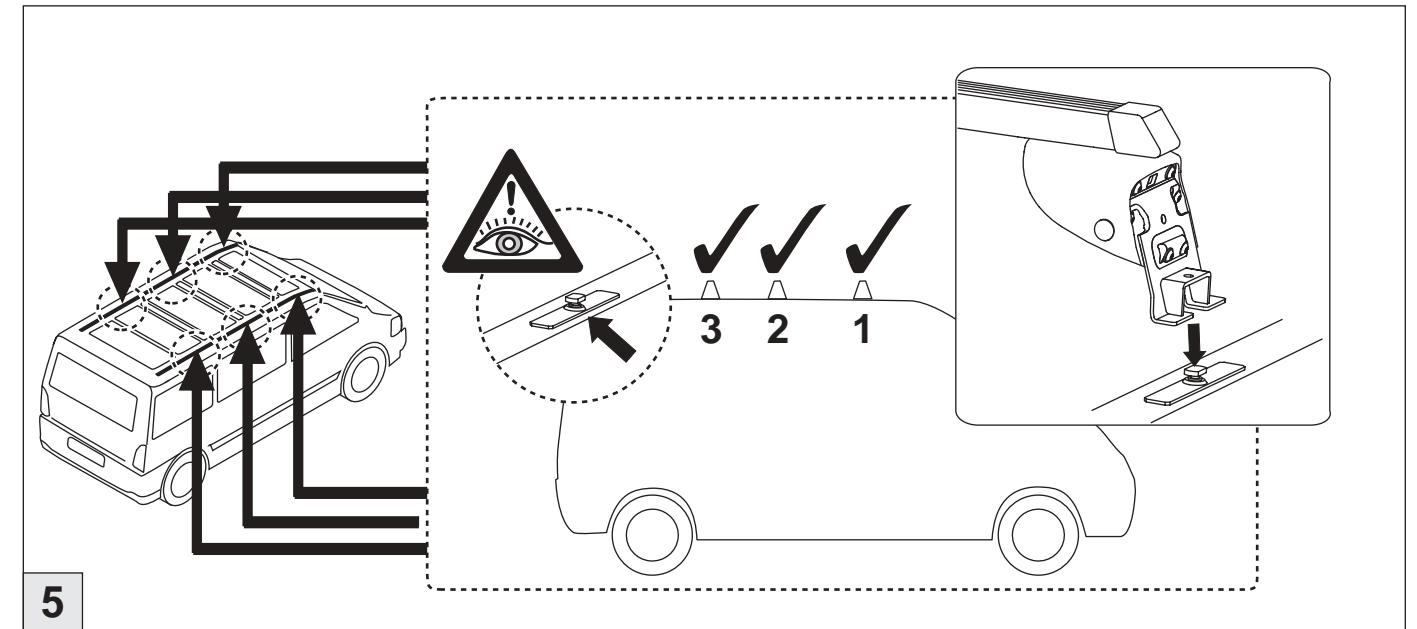

5

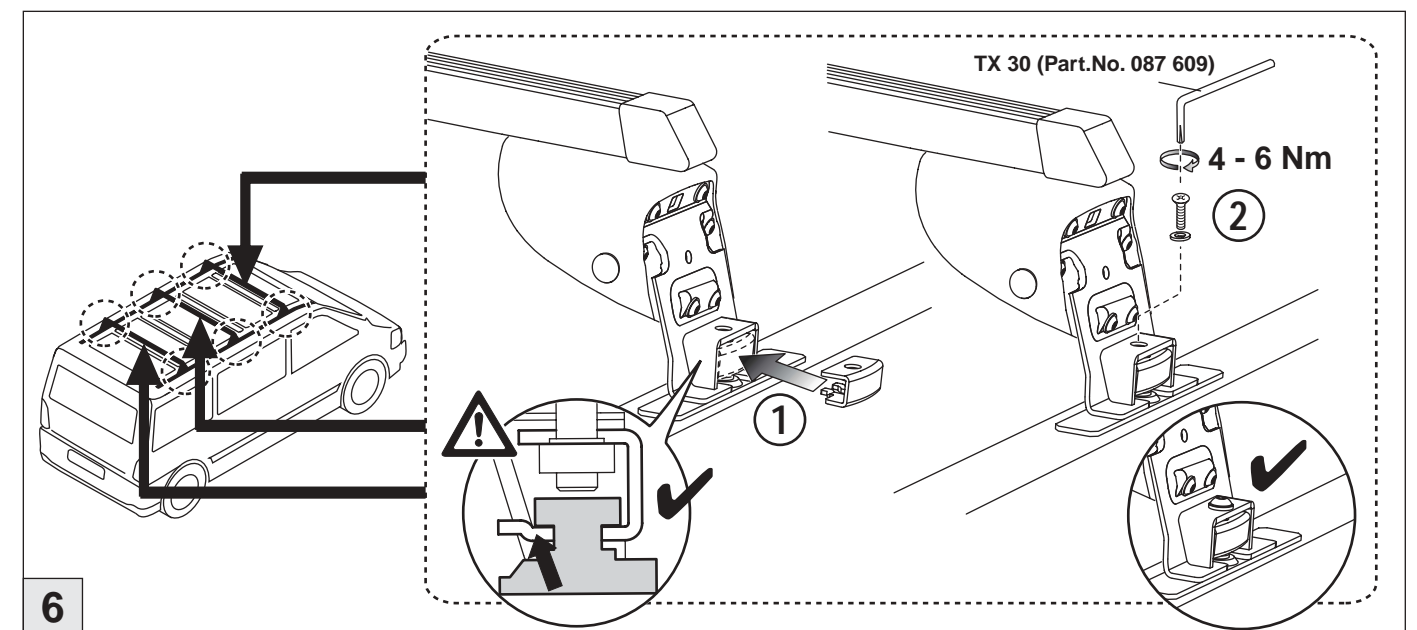

6

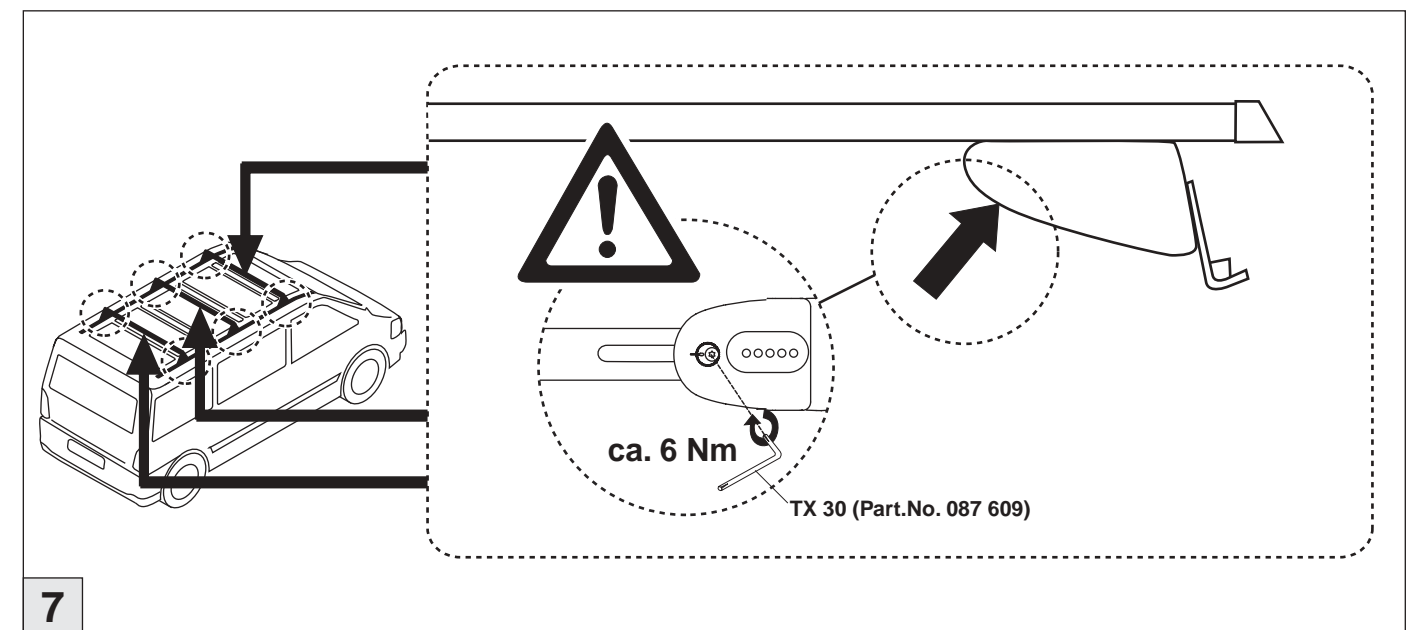

7